



SPECIAL FEATURES

- STAINLESS STEEL CASE
- RUGGED CONSTRUCTION
- DRY OR LIQUID FILLED
- STANDARD FOLLOWED IN GENERAL EN 837-1

APPLICATIONS

OIL, WATER, PNEUMATICS, HYDRAULICS, PUMP, COMPRESSORS, DIESEL ENGINES AND GASEOUS/ LIQUID MEDIA THAT WILL NOT OBSTRUCT THE PRESSURE SYSTEM.



SPECIFICATIONS

STANDARD VERSION : 40 mm, 50 mm, 63 mm, 80 mm & 100 mm

Accuracy	: ±1.6% of F. S.(For NS 63 mm, 80 mm & 100 mm) & ±2.5% of F. S.(For NS 40 mm & 50 mm)
Ambient temperature	: - 20°C to + 65°C
Process temperature	: Max 150°C
Operating Pressure Range	: 75 % of Scale Value
Over pressure limit	: ≤ 100 bar : 125% of Max. Scale Value : > 100 to ≤ 600 bar : 115% of Max. Scale Value : > 600 to ≤ 1600 bar : 110% of Max. Scale Value

Case & Bezel	: AISI 304 SS (Rolling Type) & Bayonet type for NS 80 mm
Bourdon	: Copper Alloy
Socket	: Copper Alloy
Movement	: Copper Alloy
Joints	: Alloy Brazing / Soldering

Protection	: IP 65
Dial	: Aluminum, black graduation on white background
Pointer	: Black coloured, Fixed
Window	: Plexi Glass
Filling Plug	: Neoprene
Gasket	: Neoprene /Silicon Rubber

DRY BUT FILLABLE VERSION (OPTION FG)

Fillable Dampening Liquid	: Glycerine 99.7%
Ambient Temperature	: Maximum 65°C
Process Temperature	: Maximum 65°C
Other Features	: Refer Specification of Standard Version

GLYCERINE FILLED VERSION (OPTION PY)

Accuracy	: ±1.6% of F. S.(For NS 63 mm, 80 mm & 100 mm) & ±2.5% of F. S.(For NS 40 mm & 50 mm)
Ambient Temperature	: Maximum 65°C
Process Temperature	: Maximum 65°C
Window	: Plexi Glass
Dampening Liquids	: Glycerine 99.7%
Other Features	: Refer Specification of Standard Version

Temperature effect:
The variation of indication caused by effects of temperature is to be calculated by below formula;
which is to be added in the specified accuracy while measurement :-
Formula : $\pm 0.04 \times (t_2 - t_1) \% \text{ of F. S.}$
where t_1 = reference temperature (+20°C) and t_2 = ambient temperature in °C.

DIMENSIONS - STANDARD VERSION

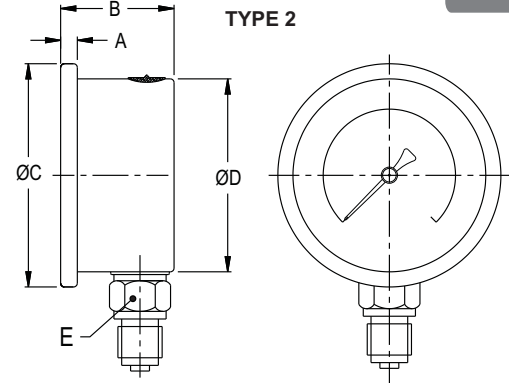
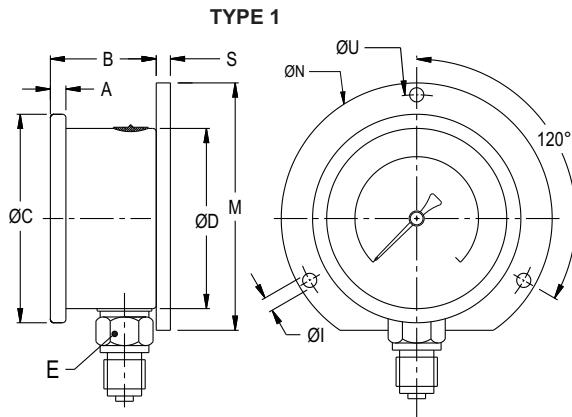

ROLLING TYPE (STANDARD)

NS	A	B	ØC	ØD	E	S	ØN	ØI	ØU	M	Weight in gram (With Box)	Weight in gram (With Glycerin & Box)
63	6.5	30	68	62.5	A/F 14	5	88	5	76	80	195.0	255.0
100	7	35.5	110	100	A/F 17	6	134	6	118	128	465.0	575.0

ROLLING TYPE (STANDARD)

NS	A	B	ØC	ØD	E	Weight in gram (With Box)	Weight in gram (With Glycerin & Box)
40	5	25	43	41	A/F 14	88.0	130.0
50	5	29	57	51.5	A/F 14	125.0	185.0
63	6.5	30	68	62.5	A/F 14	155.0	215.0
100	7	35.5	110	100	A/F 17	390.0	500.0

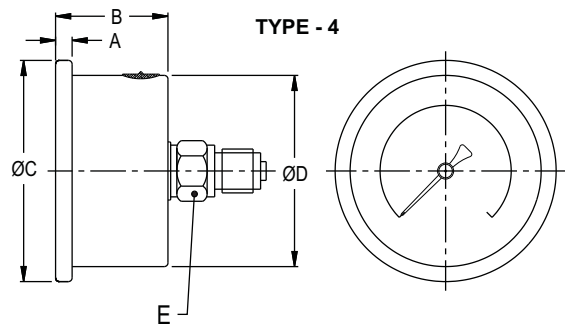
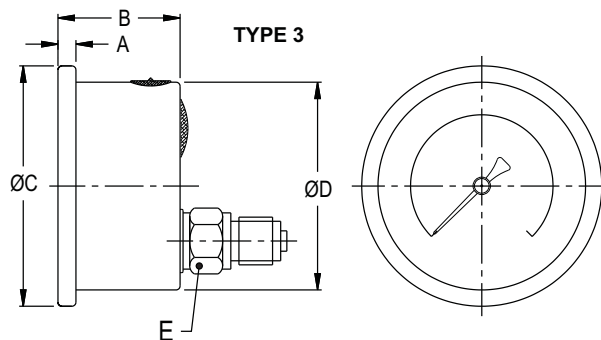

ROLLING TYPE (STANDARD)

NS	A	B	ØC	ØD	E	Weight in gram (With Box)	Weight in gram (With Glycerin & Box)
100	7	35.5	110	100	A/F 17	410.0	520.0

ROLLING TYPE (STANDARD)

NS	A	B	ØC	ØD	E	Weight in gram (With Box)	Weight in gram (With Glycerin & Box)
40	5	25	43	41	A/F 14	75.0	115.0
50	4.5	29	57.5	51.5	A/F 14	118.0	180.0
63	6.5	30	68	62.5	A/F 14	155.0	215.0

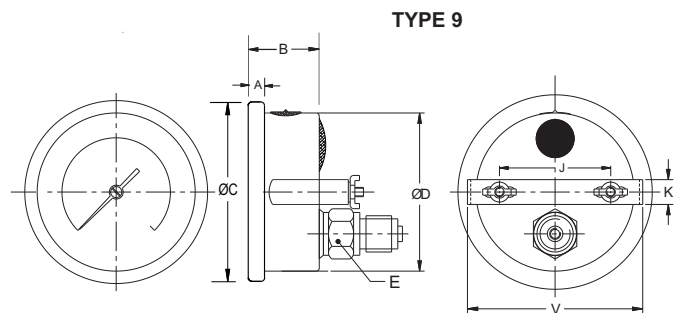
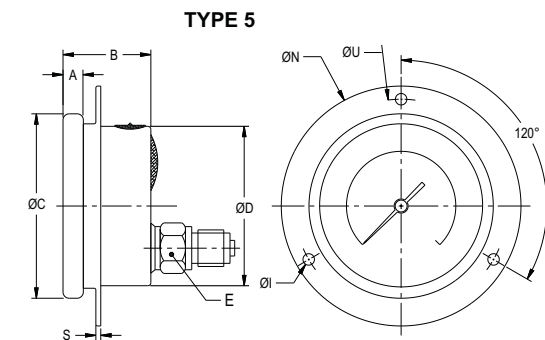

ROLLING TYPE (STANDARD)

NS	A	B	ØD	ØC	E	S	ØI	ØN	ØU	Weight in gram (With Box)	Weight in gram (With Glycerin & Box)
63	9	31	62.5	69.5	A/F 14	1	6	85.5	76	211.0	270.0
100	9	35.5	100	110	A/F 17	1	6	134	118	460.0	570.0

ROLLING TYPE (STANDARD)

NS	A	B	ØD	ØC	E	J	K	V	Weight in gram (With Box)	Weight in gram (With Glycerin & Box)
100	7	35.5	100	110	A/F 17	66.5	16	106	550.0	670.0

FOR OTHER OPTIONAL ITEMS, PLEASE CONTACT FACTORY FOR DELIVERY AND MINIMUM QUANTITY OF ORDER.

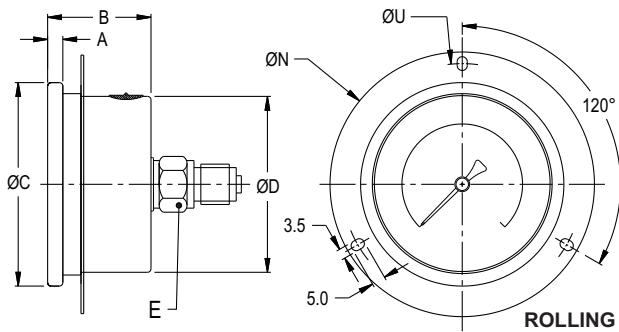

TYPE - 12

ROLLING TYPE (STANDARD)

NS	A	B	ØC	ØD	E	ØN	ØU	Weight in gram (With Box)	Weight in gram (With Glycerin & Box)
63	6.5	30	68	62.5	A/F 14	85.5	76	216.0	276.0

TYPE - 13

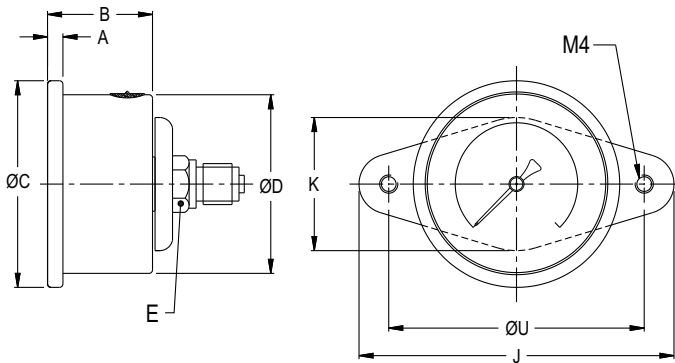

ROLLING TYPE (STANDARD)

NS	A	B	ØC	ØD	E	J	K	ØU	Weight in gram (With Box)	Weight in gram (With Glycerin & Box)
50	5	29	57	51.5	A/F 14	91	38	70.5	160.0	200.0
63	6.5	30	68	62.5	A/F 14	91	38	70.5	195.0	255.0

TYPE 1

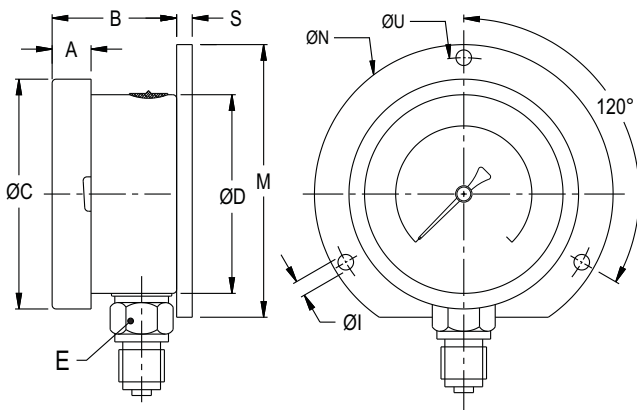

TYPE 2

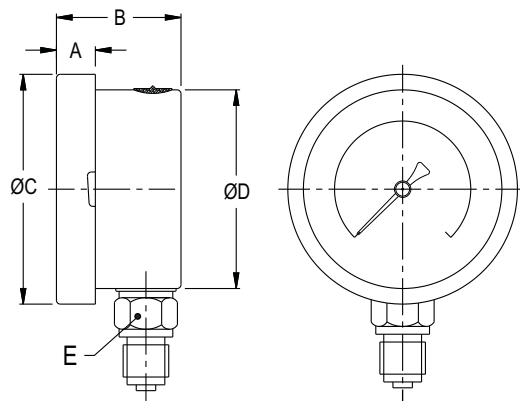

BAYONET TYPE (OPTION - OS)

NS	A	B	ØC	ØD	E	S	ØN	ØI	ØU	M	Weight in gram (With Box)	Weight in gram (With Glycerin & Box)
63	10	31	69.5	62.5	A/F 14	5	88	5	76	80	207.0	267.0
80	11	35	89.5	80	A/F 14	4	110	5	94	95	300.0	380.0
100	12.5	39	110	100	A/F 17	6	134	6	118	128	510.0	630.0

BAYONET TYPE (OPTION - OS)

NS	A	B	ØC	ØD	E	Weight in gram (With Box)	Weight in gram (With Glycerin & Box)
50	10	31	59	51	A/F 14	136.0	200.0
63	9	31	69.5	62.5	A/F 14	165.0	225.0
80	11	35	89.5	80	A/F 14	250.0	330.0
100	12.5	39	110	100	A/F 17	390.0	520.0

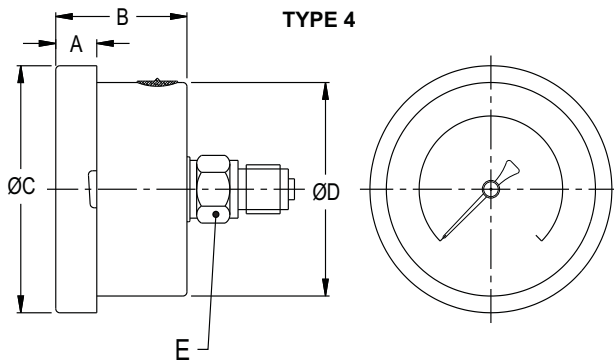

BAYONET TYPE (OPTION - OS)

NS	A	B	ØC	ØD	E	Weight in gram (With Box)	Weight in gram (With Glycerin & Box)
50	10	31	59	51	A/F 14	162.0	225.0
63	10	31	69.5	62.5	A/F 14	172.0	230.0
80	11	35	89.5	80	A/F 14	240.0	320.0

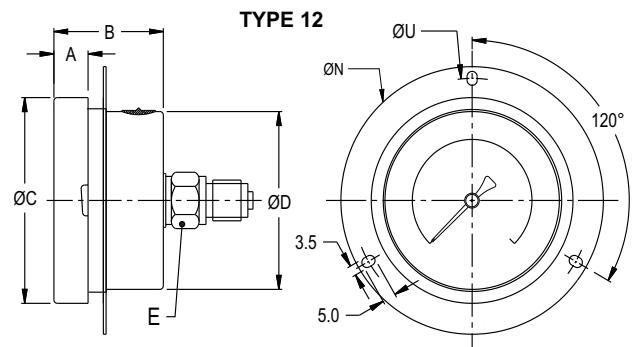
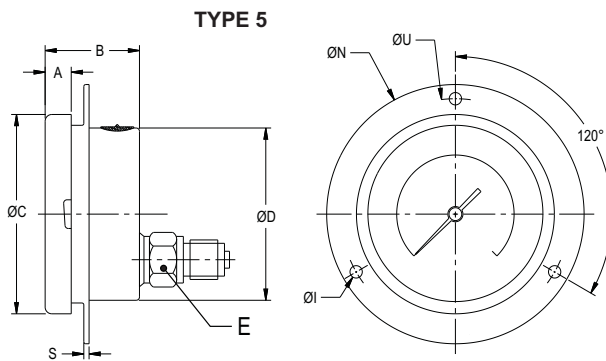

BAYONET TYPE (OPTION - OS)

NS	A	B	ØD	ØC	E	S	ØI	ØN	ØU	Weight in gram (With Box)	Weight in gram (With Glycerin & Box)
63	9	31	62.5	69.5	A/F 14	1	6	85.5	76	211.0	270.0
100	12.5	35.5	100	110	A/F 17	1	6	134	118	460.0	600.0

BAYONET TYPE (OPTION - OS)

NS	A	B	ØC	ØD	E	ØN	ØU	Weight in gram (With Box)	Weight in gram (With Glycerin & Box)
63	9	31	69.5	62.5	A/F 14	85.5	76	211.0	280.0

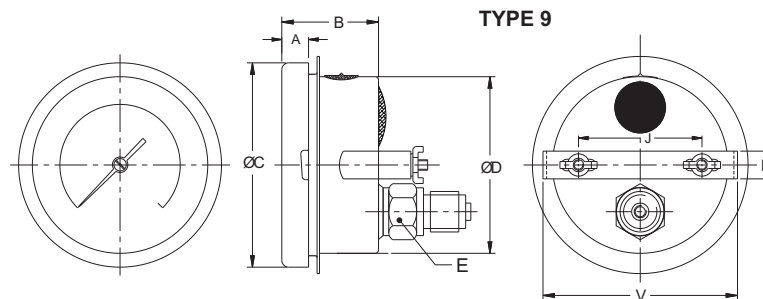

BAYONET TYPE (STANDARD)

NS	A	B	ØD	ØC	E	J	K	V	Weight in gram (With Box)	Weight in gram (With Glycerin & Box)
100	12.5	39	100	110	A/F 17	66.5	16	106	550.0	670.0

Notes : • Drawings are not to scale. • All Dimensions are in mm .• NS = Nominal Seize

• Weights mentioned are approximate and for standard product. Weight can be different after selection of options.

RANGE TABLE

Note : Waaree offers Pressure ranges, Vacuum ranges and Compound ranges in Scales like kPa, MPa, bar, psi, kg/cm² & Dual Scale like kPa with psi, kPa with bar, bar with psi or scales as per the requirement can be provided on request. Following are the example tables for kg/cm² & psi scales

RANGE WITH NOMINAL SIZES

NOMINAL SIZES		40	50	63	80	100
RANGE (psi with kg/cm ²)						
psi	kg/cm ²					
-30 inHg / 0	-760 mmHg / 0	✓	✓	✓	✓	✓
0/15 psi	0/1 kg/cm ²	✓	✓	✓	✓	✓
0/30psi	0/2 kg/cm ²	✓	✓	✓	✓	✓
0/60 psi	0/4 kg/cm ²	✓	✓	✓	✓	✓
0/100 psi	0/7 kg/cm ²	✓	✓	✓	✓	✓
0/150 psi	0/10 kg/cm ²	✓	✓	✓	✓	✓
0/220 psi	0/16 kg/cm ²	✓	✓	✓	✓	✓
0/300 psi	0/21 kg/cm ²	✓	✓	✓	✓	✓
0/400 psi	0/28 kg/cm ²	×	✓	✓	✓	✓
0/500 psi	0/35 kg/cm ²	×	✓	✓	✓	✓
0/600 psi	0/42 kg/cm ²	×	✓	✓	✓	✓
0/1000 psi	0/70 kg/cm ²	×	✓	✓	✓	✓
0/1500 psi	0/100 kg/cm ²	×	✓	✓	✓	✓
0/2200 psi	0/160 kg/cm ²	×	✓	✓	✓	✓
0/3000 psi	0/210 kg/cm ²	×	✓	✓	✓	✓
0/4000 psi	0/280 kg/cm ²	×	✓	✓	✓	✓
0/5000 psi	0/350 kg/cm ²	×	×	✓	✓	✓
0/6000 psi	0/400 kg/cm ²	×	×	✓	✓	✓
0/10000 psi	0/700 kg/cm ²	×	×	✓	✓	✓
0/15000 psi	0/1000 kg/cm ²	×	×	✓	✓	✓
- 30inHg/15	- 1/1 kg/cm ²	×	×	✓	✓	✓
- 30inHg /30	- 1/2 kg/cm ²	×	×	✓	✓	✓
- 30inHg /60	- 1/4 kg/cm ²	×	×	✓	✓	✓
- 30inHg /100	- 1/7 kg/cm ²	×	×	✓	✓	✓
- 30inHg /150	- 1/10 kg/cm ²	×	×	✓	✓	✓
- 30inHg /200	- 1/14 kg/cm ²	×	×	✓	✓	✓
- 30inHg /300	- 1/21 kg/cm ²	×	×	✓	✓	✓

FREON WITH TEMPERATURE SCALE

Note : For temperature scales, please provide refrigerant name.

- 30" Hg / 150 psi	×	×	✓	✓	✓
- 30" Hg / 300 psi	×	×	✓	✓	✓
0/300 psi	×	×	✓	✓	✓
0/500 psi	×	×	✓	✓	✓

ACCESSORIES (Refer Datasheet for complete specifications)

EC	GAUGE COCK	EG	SNUBBER
ED	OVERLOAD PROTECTOR (GAUGE SAVER)**	EH	SIPHON
*	NEEDLE VALVE		

* Refer catalogue for Valves & Manifolds

** For Pressure Ranges.

HOW TO ORDER

Example

BASIC MODEL

AT

CODE

NOMINAL SIZE

B	C	D	E	F
40 mm	50 mm	63 mm	80 mm	100 mm

X

TYPE OF MOUNTING

	B	C	D	E	F
1 WALL/ SURFACE/ PROJECTION MOUNTING WITH BOTTOM ENTRY	X	X	✓	✓	✓
2 DIRECT BOTTOM ENTRY	✓	✓	✓	✓	✓
3 DIRECT LOWER BACK ENTRY	X	X	X	X	✓
4 DIRECT CENTER BACK ENTRY	✓	✓	✓	✓	X
5 LOWER BACK ENTRY WITH FRONT FLANGE	X	X	✓	X	✓
9 LOWER BACK ENTRY WITH MOUNTING BRACKET	X	X	X	X	✓
12 CENTER BACK ENTRY WITH FRONT FLANGE	X	X	✓	X	X
13 CENTER BACK ENTRY WITH MOUNTING BRACKET	X	✓*	✓*	X	X

X
OR
XX

Note : *Available in Rolling type design only.

GAUGE CONNECTION

	B	C	D	E	F
1BM 1/8" BSP(M)	✓	✓	✓	X	X
1NM 1/8" NPT(M)	✓	✓	✓	X	X
1TM 1/8" BSPT(M)	✓	✓	✓	X	X
2BM 1/4" BSP(M)	X	✓	✓	✓	✓
2NM 1/4" NPT(M)	X	✓	✓	✓	✓
2TM 1/4" BSPT(M)	X	✓	✓	✓	✓
3BM 3/8" BSP(M)	X	X	X	✓	✓
3NM 3/8" NPT(M)	X	X	X	✓	✓
3TM 3/8" BSPT(M)	X	X	X	✓	✓
4BM 1/2" BSP(M)	X	X	X	✓*	✓*
4NM 1/2" NPT(M)	X	X	X	✓*	✓*
4TM 1/2" BSPT(M)	X	X	X	✓*	✓*

XXX

* These connections are also available on request. Consult factory for minimum order quantity, price & delivery.

Note : Connections like Metric/ PT/ PF/ Flaired/ UNF/ G/ R etc. can be provided on request.

RANGE

0/10
kg/cm²

REFER RANGE TABLE

OPTIONAL EXTRAS

RH CUSTOM DESIGNED DIAL	SX SS TAG PLATE
SG OXYGEN SERVICE (FOR DRY VERSION)	TB HELIUM LEAK TEST
PW FIVE POINT CALIBRATION CERTIFICATE	FG FILLABLE LIQUID GLYCERINE
PY DAMPENING LIQUID GLYCERINE FILLED	FK INTEGRAL DAMPENING SCREW (BRASS)
RI 25 MM BOD (EXCEPT MOUNTING 4, 12 & 13)*	ZC FREON RANGE (WITH TEMPERATURE SCALE)*
OS CASE WITH BAYONET TYPE BEZEL***	RX SHATTERPROOF GLASS/ SAFETY GLASS (FOR BAYONET TYPE DESIGN)*
RR ENCLOSURE PROTECTION IP 66	RZ TOUGHENED GLASS (FOR BAYONET TYPE DESIGN)*
RE ENCLOSURE PROTECTION IP 67	SF MOVEMENT WITH DAMPENING JELLY*

XX

* Applicable for NS 63 mm, 80 mm & 100 mm.*** Applicable for NS 50 mm, 63 mm & 100 mm.

Ordering Example: AT - X - X OR XX - XXX - 0/10 kg/cm² - XX

FOR OTHER OPTIONAL ITEMS, PLEASE CONTACT FACTORY FOR DELIVERY AND MINIMUM QUANTITY OF ORDER.

Note : Specifications and dimensions given in this product catalogue represents the state of engineering at the time of printing.
Modifications may take place and materials specified may be replaced by others without prior notice.